

# **IEEE Standard for Threaded Zinc-Coated Ferrous Strand-Eye Anchor Rods and Nuts for Overhead Line Construction**

Sponsor

**Transmission and Distribution Committee  
of the  
IEEE Power Engineering Society**

Approved 16 September 1999

**IEEE-SA Standards Board**

**Abstract:** Requirements for threaded zinc-coated ferrous strand-eye anchor rods and nuts commonly used in overhead line construction are covered in this standard.

**Keywords:** Anchor rods, anchor rod threads, bend test, nuts, nut threads, strand-eye, tensile load test, zinc-coated.

---

The Institute of Electrical and Electronics Engineers, Inc.  
3 Park Avenue, New York, NY 10016-5997, USA

Copyright © 1999 by the Institute of Electrical and Electronics Engineers, Inc.  
All rights reserved. Published 30 December 1999. Printed in the United States of America.

Print: ISBN 0-7381-1843-5 SH94804  
PDF: ISBN 0-7381-1844-3 SS94804

No part of this publication may be reproduced in any form, in an electronic retrieval system or otherwise, without the prior written permission of the publisher.

**IEEE Standards** documents are developed within the IEEE Societies and the Standards Coordinating Committees of the IEEE Standards Association (IEEE-SA) Standards Board. Members of the committees serve voluntarily and without compensation. They are not necessarily members of the Institute. The standards developed within IEEE represent a consensus of the broad expertise on the subject within the Institute as well as those activities outside of IEEE that have expressed an interest in participating in the development of the standard.

Use of an IEEE Standard is wholly voluntary. The existence of an IEEE Standard does not imply that there are no other ways to produce, test, measure, purchase, market, or provide other goods and services related to the scope of the IEEE Standard. Furthermore, the viewpoint expressed at the time a standard is approved and issued is subject to change brought about through developments in the state of the art and comments received from users of the standard. Every IEEE Standard is subjected to review at least every five years for revision or reaffirmation. When a document is more than five years old and has not been reaffirmed, it is reasonable to conclude that its contents, although still of some value, do not wholly reflect the present state of the art. Users are cautioned to check to determine that they have the latest edition of any IEEE Standard.

Comments for revision of IEEE Standards are welcome from any interested party, regardless of membership affiliation with IEEE. Suggestions for changes in documents should be in the form of a proposed change of text, together with appropriate supporting comments.

Interpretations: Occasionally questions may arise regarding the meaning of portions of standards as they relate to specific applications. When the need for interpretations is brought to the attention of IEEE, the Institute will initiate action to prepare appropriate responses. Since IEEE Standards represent a consensus of all concerned interests, it is important to ensure that any interpretation has also received the concurrence of a balance of interests. For this reason, IEEE and the members of its societies and Standards Coordinating Committees are not able to provide an instant response to interpretation requests except in those cases where the matter has previously received formal consideration.

Comments on standards and requests for interpretations should be addressed to:

Secretary, IEEE-SA Standards Board  
445 Hoes Lane  
P.O. Box 1331  
Piscataway, NJ 08855-1331  
USA

<p>Note: Attention is called to the possibility that implementation of this standard may require use of subject matter covered by patent rights. By publication of this standard, no position is taken with respect to the existence or validity of any patent rights in connection therewith. The IEEE shall not be responsible for identifying patents for which a license may be required by an IEEE standard or for conducting inquiries into the legal validity or scope of those patents that are brought to its attention.</p>
---

Authorization to photocopy portions of any individual standard for internal or personal use is granted by the Institute of Electrical and Electronics Engineers, Inc., provided that the appropriate fee is paid to Copyright Clearance Center. To arrange for payment of licensing fee, please contact Copyright Clearance Center, Customer Service, 222 Rosewood Drive, Danvers, MA 01923 USA; (978) 750-8400. Permission to photocopy portions of any individual standard for educational classroom use can also be obtained through the Copyright Clearance Center.

## Introduction

(This introduction is not a part of IEEE Std C135.2-1999, IEEE Standard for Threaded Zinc-Coated Ferrous Strand-Eye Anchor Rods and Nuts for Overhead Line Construction.)

This standard covers the requirements for threaded strand-eye anchor rods and nuts commonly used in overhead line construction.

## Participants

At the time this standard was completed, the Working Group on Pole Line Hardware of the Transmission and Distribution Committee of the IEEE Power Engineering Society had the following membership:

**Ronald J. Oedemann, Chair**

**Chris Severs, Vice-Chair**

Nick Annas  
James D. Applequist  
Frederick W. Burtelson  
Edward Dziedzic  
Thomas Evison  
John Farrington  
Donald G. Heald

Richard W. Hensel  
Nunnally Johnson  
Ralph O. Jones  
Edward A. Kiernozek  
Robert O. Kluge  
David J. Koury  
Keith E. Lindsey

Robert C. Peters  
Patrick D. Quinn  
Karl F. Reed II  
Steven D. Scholfield  
Steve Smith  
Lewis M. Whisonant  
Cary H. Yuan

The following members of the balloting committee voted on this standard:

James E. Applequist  
R. Allen Bernstorf  
Nelson G. Bingel  
James F. Christensen  
F. Leonard Consalvo  
Glenn A. Davidson  
Frank A. Denbrock  
Nicholas J. DeSantis  
John Farrington

Jon M. Ferguson  
Richard W. Hensel  
Ralph O. Jones  
Jurgen O. C. Kansog  
Leon Kempner  
Edward A. Kiernozek  
A. Lux  
Y. Jakov Motlis  
Ronald J. Oedemann

Carlos Peixoto  
Robert C. Peters  
Patrick D. Quinn  
R.V. Rebbapragada  
John Rumble  
Donald Sandell  
Chris Severs  
Doug Sherman  
Dave Sunkle

When the IEEE-SA Standards Board approved this standard on 16 September 1999, it had the following membership:

**Richard J. Holleman, Chair**

**Donald N. Heirman, Vice Chair**

**Judith Gorman, Secretary**

Satish K. Aggarwal  
Dennis Bodson  
Mark D. Bowman  
James T. Carlo  
Gary R. Engmann  
Harold E. Epstein  
Jay Forster\*  
Ruben D. Garzon

James H. Gurney  
Lowell G. Johnson  
Robert J. Kennelly  
E. G. "Al" Kiener  
Joseph L. Koepfinger\*  
L. Bruce McClung  
Daleep C. Mohla  
Robert F. Munzner

Louis-François Pau  
Ronald C. Petersen  
Gerald H. Peterson  
John B. Posey  
Gary S. Robinson  
Akio Tojo  
Hans E. Weinrich  
Donald W. Zipse

\*Member Emeritus

Also included is the following nonvoting IEEE-SA Standards Board liaison:

Robert E. Hebner

Andrew D. Ickowicz  
*IEEE Standards Project Editor*

# Contents

1.	Overview.....	1
1.1	Scope.....	1
1.2	Purpose.....	1
2.	References.....	1
3.	Anchor rods.....	1
3.1	Dimensions .....	2
3.2	Nuts for anchor rods.....	2
4.	Threads.....	2
4.1	Anchor-rod threads .....	2
4.2	Nut threads .....	3
5.	Tests for strength.....	3
5.1	Tensile load test .....	3
5.2	Bend test.....	4
6.	Sizes .....	4
7.	Corrosion protection .....	4
8.	Finish .....	4
9.	Marking of anchor rods.....	4
10.	Marking of shipments .....	4

# IEEE Standard for Threaded Zinc-Coated Ferrous Strand-Eye Anchor Rods and Nuts for Overhead Line Construction

## 1. Overview

### 1.1 Scope

This standard covers the requirements for threaded zinc-coated ferrous strand-eye anchor rods and nuts commonly used in overhead line construction. Metric anchor rods and nuts are not covered by this standard.

### 1.2 Purpose

Anchor rods and nuts conforming to the requirements of this standard shall, in all respects, meet the basic dimensional and performance requirements hereinafter stated. The text, tabular specifications, references to other standards, and figures supplement each other and shall be considered as parts of this standard.

## 2. References

This standard shall be used in conjunction with the following publications:

ANSI/ASME B18.2.2-87 (R1999), American National Standard for Square and Hex Nuts.<sup>1</sup>

ASTM A153/A153M-98, Standard Specification for Zinc Coating (Hot-Dip) on Iron and Steel Hardware.<sup>2</sup>

## 3. Anchor rods

All anchor rods shall be made from hot-rolled steel produced by the open-hearth, basic-oxygen, or electric furnace process and shall be of a grade and quality to meet the requirements of this standard.

---

<sup>1</sup>ANSI publications are available from the Sales Department, American National Standards Institute, 11 West 42nd Street, 13th Floor, New York, NY 10036, USA (<http://www.ansi.org/>). ASME publications are available from the American Society of Mechanical Engineers, 3 Park Avenue, New York, NY 10016-5990, USA (<http://www.asme.org/>).

<sup>2</sup>ASTM publications are available from the American Society for Testing and Materials, 100 Barr Harbor Drive, West Conshohocken, PA 19428-2959, USA (<http://www.astm.org/>).

### 3.1 Dimensions

All dimensions before zinc coating shall be in accordance with those shown in Figure 1.

### 3.2 Nuts for anchor rods

All anchor rods shall be furnished with one square nut per rod unless otherwise specified. The nuts shall be assembled on the rods; suitable means shall be provided for preventing loss in transit. The nuts shall be of the heavy-duty square type and shall meet the requirements of ANSI/ASME B18.2.2-87.<sup>3</sup> Dimensions for nuts, before zinc coating, shall be in accordance with Table 1.

**Table 1—Dimensions of heavy-duty square nuts, in inches (before galvanizing)**

Nominal bolt size	Width across flats			Width across corners		Thickness		
	Basic	Max.	Min.	Max.	Min.	Basic	Max.	Min.
5/8	1 1/16	1.0625	1.031	1.503	1.386	5/8	0.647	0.587
3/4	1 1/4	1.2500	1.212	1.768	1.635	3/4	0.771	0.710
1	1 5/8	1.6250	1.575	2.298	2.132	1	1.028	0.956

NOTES:

1—The maximum width across the flats shall not be exceeded. No transverse section through the nut, between 25% and 75% of the nut thickness, as measured from the bearing face, shall be less than the minimum width across the flats.

2—The tops of the nuts shall be flat and shall be chamfered or washer crowned. The diameter of the chamfer circle shall be equal to the maximum width across the flats, within a tolerance of  $-15\%$ .

3—The bearing surface shall be at right angles to the axis of the threaded hole, within a tolerance of  $3^\circ$ .

4—The axis of the tapped hole shall be concentric with the axis of the nut body, within a tolerance equal to 5% [10% full indicator reading (FIR)] of the maximum width across the flats.

## 4. Threads

### 4.1 Anchor-rod threads

Anchor-rod threads shall, before zinc coating, be concentric with the axis of the rod and shall be machine rolled or cut in accordance with the dimensions given in Table 2.

**Table 2—Dimension of anchor-rod threads (in inches)**

Nominal rod size	Rolled or cut	Series and class	Rod diameter		Major diameter		Pitch diameter	
			Max.	Min.	Max.	Min.	Max.	Min.
5/8	R	11-UNS-2A	0.616	0.602	0.6718	0.6536	0.6113	0.6058
3/4	R	10-UNS-2A	0.742	0.726	0.8034	0.7841	0.7364	0.7305
1	C	8-UNC-2A	1.009	0.975	0.9980	0.9755	0.9168	0.9100

<sup>3</sup>Information on references can be found in Clause 2.

For roll-threaded products made from hot-rolled bars, some variations from the dimensions given in Table 2 may be expected due to American Iron and Steel Institute (AISI) diameter tolerances. After zinc coating, the external threaded portion of all anchor rods shall be in such a condition that nuts, tapped in accordance with Table 3, will fit the rods and can be run the entire length of the thread without the use of tools.

**Table 3—Dimension of anchor-rod nut threads (in inches)**

Nominal rod size	Threads per inch	Pitch diameter		Minor diameter		Major diameter	Nominal tap size
		Min.	Max.	Min.	Max.	Min.	
5/8	11	0.6354	0.6426	0.5964	0.6154	0.6944	0.695-11
3/4	10	0.7613	0.7690	0.7183	0.7393	0.8263	0.826-10
1	8	0.9398	0.9486	0.8860	0.9110	1.0210	1.021-8

## 4.2 Nut threads

After zinc coating, anchor-rod nut threads shall be tapped oversize in accordance with the dimensions given in Table 3.

## 5. Tests for strength

### 5.1 Tensile load test

Any assembled anchor rod, when tested by restraining the nut and applying a load by a suitable means through the eye of the rod, shall withstand the following tensile loads:

Nominal rod size	Minimum load
5/8	71 kN (16 000 lbf)
3/4	102 kN (23 000 lbf)
1	160 kN (36 000 lbf)

If failure occurs, it shall occur only in the shank or the threaded section of the anchor rod.

If desired, this test may be made in two steps:

- *Step 1:* Apply a tensile load to the unthreaded portion of the rod and to a bar passing through the eye of the rod.
- *Step 2:* Apply a tensile load to the unthreaded portion of the rod while restraining the nut.

In Step 2, at least three full threads of the threaded rods shall extend beyond the face of the nut.

## 5.2 Bend test

It shall be possible, while the assembled anchor rod is at room temperature [10–32° C (50–90° F)] to bend any point of the unthreaded portion of the rod through an angle of 90°, about a mandrel equal to the diameter of the anchor rod, without fracture of the steel. Spalling or cracking of the zinc coating in this test shall not be deemed failure to meet this requirement.

## 6. Sizes

Anchor-rod sizes in inches and lengths in feet shall be as given in Table 4.

**Table 4—Nominal anchor-rod sizes**

Nominal rod size (inches)	Length (ft)		
	Single-strand eye-type	Double-strand eye-type	Triple-strand eye-type
5/8	6, 7, 8	6, 7, 8	—
3/4	8	7, 8, 9	7, 8, 9
1	—	10	8, 10

## 7. Corrosion protection

All anchor rods and nuts shall be zinc-coated. The coating shall be applied by

- a) The hot dip process in accordance with ASTM A153/A153M-98, or
- b) Another method producing a zinc coating that meets the requirements of ASTM A153/A153M-98 for adhesion, purity, and thickness applicable to the class of material being coated.

## 8. Finish

- Anchor rods shall be free from burrs and irregular surfaces that affect serviceability.
- Anchor rods shall be free from badly formed, rough, or cracked eyes.
- The inner surfaces of the anchor rod eyes that contact the strand shall be smooth and free from projections.

## 9. Marking of anchor rods

All anchor rods shall be permanently marked near the eye with

- a) The manufacturer’s symbol (or identification); and
- b) The length of the rod.

## 10. Marking of shipments

Each shipment of anchor rods shall be marked with the vendor’s name and catalog number.

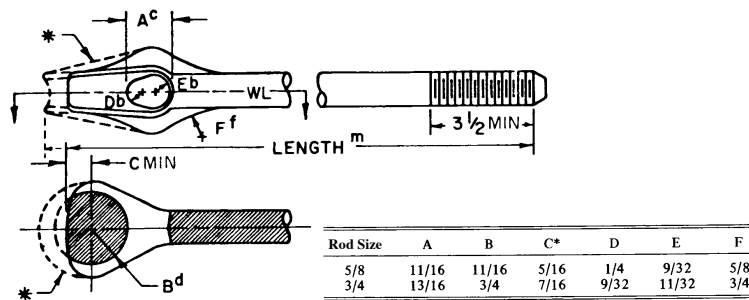

Single Strand-Eye Anchor Rod

(a)

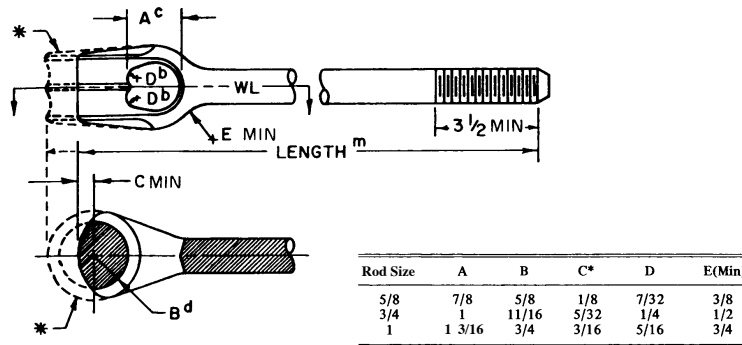

Double Strand-Eye Anchor Rod

(b)

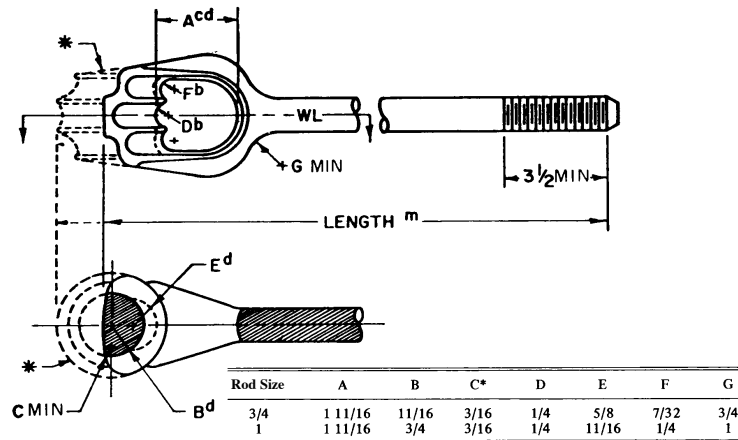

Triple Strand-Eye Anchor Rod

(c)

\*Full circle dimension is optional and when used, dimension C should be disregarded.

NOTES: W = Manufacturer's identification, L = Length  
ALLOWABLE VARIATIONS: a = 1/64, b = 1/32, c = 1/16, d = 1/8, e = 3/16, f = 1/4, g = 3/8, h = 1/2, j = 3/4, k = 1, m = 3, x = 0

A single-letter superscript indicates that the plus and minus value are the same, for example:

D<sup>b</sup> = 1/4 ± 1/32 for 5/8-inch single strand-eye anchor rods.

A double-letter superscript indicates that the plus value is that of the first letter and the minus value is that of the second letter, for example:

A<sup>cd</sup> = 1 11/16, + 1/16, - 1/8 inch for 3/4-inch triple strand-eye anchor rods.

Figure 1—Dimensions for single, double, and triple strand-eye anchor rods (in inches)